

Code No: 133BJ

JAWAHARLAL NEHRU TECHNOLOGICAL UNIVERSITY HYDERABAD**B.Tech II Year I Semester Examinations, November/December - 2017****NETWORK ANALYSIS****(Electronics and Communication Engineering)****Time: 3 Hours****Max. Marks: 75****Note:** This question paper contains two parts A and B.

Part A is compulsory which carries 25 marks. Answer all questions in Part A.

Part B consists of 5 Units. Answer any one full question from each unit.

Each question carries 10 marks and may have a, b, c as sub questions.

PART- A**(25 Marks)**

- 1.a) Define Graph, Tree, Basic Cut set and Basic Tie set. Illustrate with an example. [2]
- b) Explain Active elements in detail. [3]
- c) Derive the relation between voltage and current in a series connected RL Circuits. [2]
- d) Draw a power triangle in series connected RLC networks. [3]
- e) Derive the relation between RMS and maximum value. [2]
- f) Define form factor and peak factor. [3]
- g) Define characteristic impedance. [2]
- h) Define image and iterative impedance. [3]
- i) Draw and explain T section network. [2]
- j) Explain about LC Filters. [3]

PART-B**(50 Marks)**

- 2.a) What is an electric circuit? What is a magnetic circuit? Make a comparison between electric circuit and magnetic circuit.
- b) Coil 1 of a pair of coupled coils has a continuous current of 5A, and the corresponding fluxes ϕ_{11} and ϕ_{12} are 0.2 and 0.4 mWb respectively. If the turns are $N_1 = 500$ and $N_2 = 1500$, find L_1 , L_2 , M and k . [5+5]

OR

- 3.a) For the network shown in below Figure 1 find Z_{ab} and I_o .

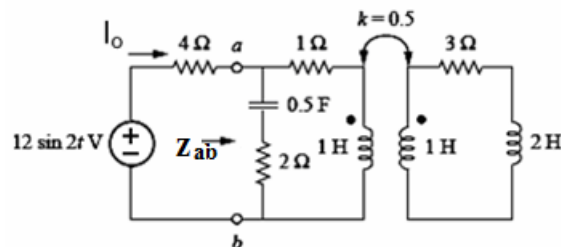
**Figure: 1**

- b) Find the input impedance of the circuit shown in Figure 2. Assume that the circuit operates at $\omega = 50$ rad/s. [5+5]

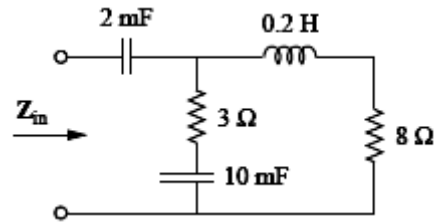

Figure: 2

- 4.a) Obtain the current locus of a fixed resistance and a variable capacitance.
 b) Given a series RLC circuit with $R = 10$ ohms, $L = 1$ mH and $C = 1$ μ F is connected across a sinusoidal source of 20 V with variable frequency. Find: i) The resonant frequency ii) Q factor of the circuit at resonant frequency iii) Half power frequencies [5+5]

OR

- 5.a) Derive and draw the response of a series RLC circuit for step input.
 b) An impedance $Z_1 = 10 + j10$ Ω is connected in parallel with another impedance of resistance 8.5 Ω and a variable capacitance connected in series. Find C such that the circuit is in resonance at 5 KHz. [5+5]

6. A series-connected RLC circuit has $R = 4$ and $L = 25$ mH:
 a) Calculate the value of C that will produce a quality factor of 50.
 b) Find ω_1 , ω_2 , and B.
 c) Determine the average power dissipated at $\omega = \omega_0$, ω_1 , ω_2 . Take $V_m = 100$ V. [3+3+4]

OR

- 7.a) Obtain the current locus of a series circuit having a fixed resistance and a variable inductance.
 b) Given a series RLC circuit with $R = 100$ ohms, $L = 0.5$ H and $C = 40$ μ F, Calculate the resonant, lower and upper half – power frequencies. [5+5]
8. Explain clearly the terms:
 a) Characteristic Impedance and
 b) Image Transfer Constant. [5+5]

OR

- 9.a) Define Hybrid parameters of a Two Port network. Establish the relation between Hybrid Parameters and ABCD Parameters.
 b) A symmetrical T-section has an inductance of 0.47H in each series arm and a 300 μ F capacitor in the shunt arm.
 i) Find the characteristic impedance at frequencies of 50 Hz and 100 Hz.
 ii) If the T-section is terminated in the characteristic impedance, find the ratio of load current to input current at both the frequencies. [5+5]

- 10.a) What is a high pass filter? In what respects it is different from a low pass filter?
b) Derive the equations to find the inductances and capacitances of a constant K high pass filter. [5+5]

OR

- 11.a) What is an LC immittance function? State the properties of such functions.
b) Design a constant 'K' T-section low pass filter having cutoff frequency of 2 kHz and nominal characteristic impedance of 600 ohms. [5+5]

---oo0oo---

II B. Tech I Semester Supplementary Examinations, May - 2018

NETWORK ANALYSIS

(Com to ECE, EIE and ECC)

Time: 3 hours

Max. Marks: 70

- Note: 1. Question Paper consists of two parts (**Part-A** and **Part-B**)
 2. Answer **ALL** the question in **Part-A**
 3. Answer any **FOUR** Questions from **Part-B**

PART -A

1. a) Explain the terms i) Resistivity and ii) Conductivity and give its units (2M)
- b) Define the following terms w.r.t network Graph theory: (3M)
 i) Connected graph ii) Tree iii) Links
- c) Explain the term Quality factor of a circuit in resonance (2M)
- d) State the Norton's Theorem (3M)
- e) What are the conditions to be fulfilled for reciprocity of a two port network (2M)
- f) Distinguish between Homogeneous and Non -Homogeneous equations (2M)

PART -B

2. a) Explain the principle of Duality with an example (7M)
- b) Using node analysis, find I for the circuit diagram shown below: (7M)

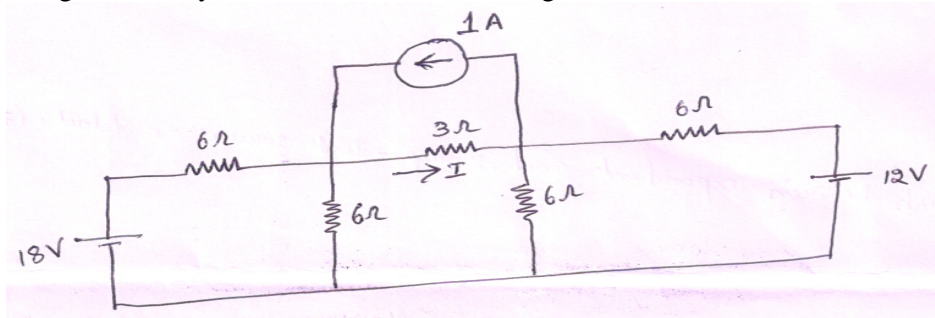

3. a) Prove that in a pure inductive circuit the active power supplied over a complete cycle averages out to Zero. (7M)
- b) A certain inductive coil takes 15A when the supply voltage is 230 V, 50 Hz. If the frequency is changed to 40 Hz, the current increases to 17.2 A. Calculate the resistance and the inductance of the coil. (7M)
4. a) Derive the equation for Equivalent inductance , when two inductors are coupled in series opposing and mutual inductance exists between them (6M)
- b) A coil of resistance 50Ω and inductance 9H is connected in series with a capacitor and is supplied at constant voltage and variable frequency source. If the maximum current is 1A at 75 Hz determine the frequencies when the current is 0.5A. (8M)



5. Use Thevenin's theorem to find the current I that will flow through the switch S in the circuit shown in figure, when S is closed. Specify the direction as well as the magnitude of I (14M)

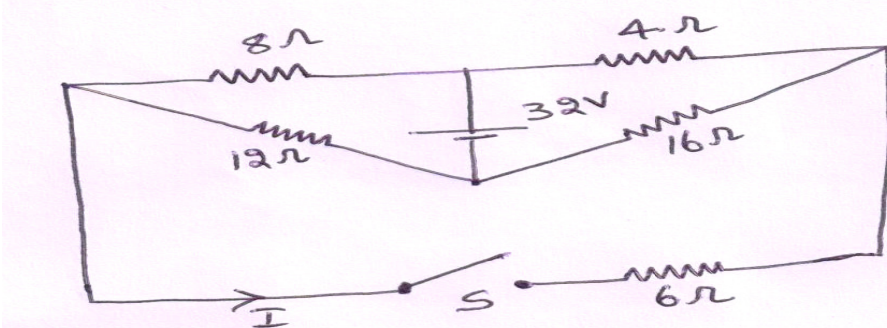

6. a) Explain the interrelationships between Z-parameters in terms of ABCD - parameters for a two port network (7M)
 b) For the network shown, determine Y_{11} and Y_{21} with $3\ \Omega$ load across port 2. (7M)

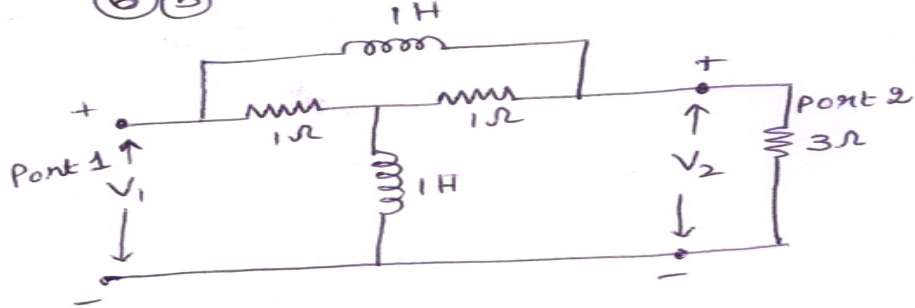

7. a) Derive the step response of RL circuit in s-domain (5M)
 b) The network shown in figure, is initially under steady state condition. The switch is opened at $t=0$. Find the voltage across inductance as a function of t . (9M)

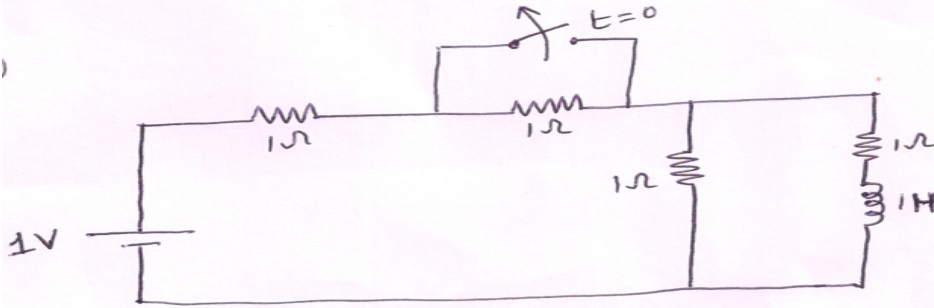

II B. Tech I Semester Model Question Papers Sept-2017

NETWORK ANALYSIS

(Common to ECE, EIE, E Com.E Branches)

Time: 3 hours

Max. Marks: 70

Question Paper Consists of **Part-A** and **Part-B**
 Answering the question in **Part-A** is Compulsory,
 FOUR Questions should be answered from **Part-B**

PART-A

- 1.(i) Define electric potential, electric current and electric energy.
- (ii) A certain inductive coil takes 15 A when the supply voltage is 230 V, 50 Hz. If the frequency is changed to 40 Hz, the current increases to 17.2 A. Calculate resistance and inductance of the coil.
- (iii) Write the differences between series and parallel resonance.
- (iv) State compensation theorem.
- (v) Write the Z-parameters of the following network (Figure:1):

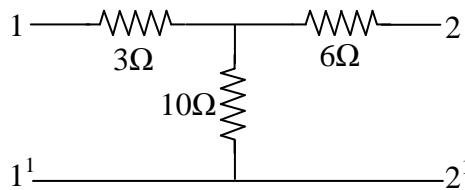

Figure:1

- (vi) What is time constant? What are the time constant of series R-L and R-C circuit?
- (vii) A series R-L circuit has R=20 ohms and L=8 H. The circuit is connected across a DC voltage source of 120 V at t=0. Calculate the time at which the voltage drops across R and L are the same.

[2+2+2+2+2+2+2]

PART-B

- 2.(a) State and explain Kirchhoff's voltage and current law with an example.
- (b) Find the voltage V(t) in the network shown in figure:2 using nodal technique. All impedances are in ohms.

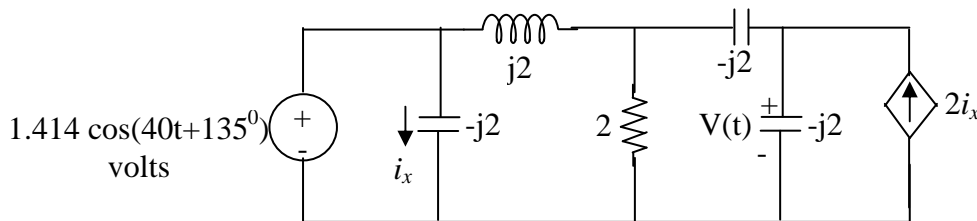

Figure:2

[6+8]



- 3.(a) A sinusoidal 50 Hz voltage of 200 V supplies three parallel circuits as shown in figure:3. Find the current in each circuit and the total current. Draw the vector diagram. Assume supply voltage $V=200V$, 50 Hz.

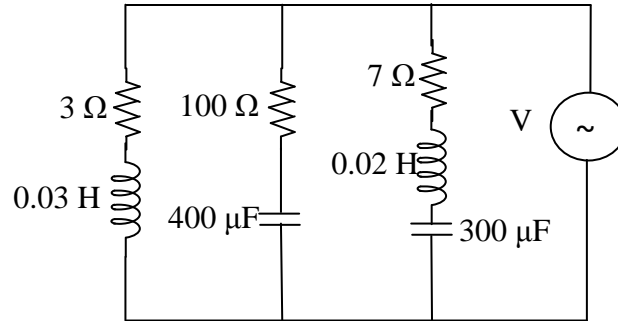

Figure:3

- (b) The impedances of a parallel circuit are $Z_1=(6 + j8)$ ohms and $Z_2 = (8 - j6)$ ohms. If the applied voltage is 120V, find (i) current and power factor of each branch (ii) overall current and power factor of the combination (iii) power consumed by each impedance. Draw a phasor diagram. [7+7]
- 4.(a) Obtain an expression for coefficient of coupling.
 (b) Two similar coils connected in series gave a total inductance of 600 mH and when one of the coil is reversed, the total inductance is 300 mH. Determine the mutual inductance between the coils and coefficient of coupling.
 (c) State and explain Maximum power transfer theorem. [4+5+5]
- 5.(a) For a series resonant circuit with constant voltage and variable frequency, obtain the frequency at which voltage across the inductor is maximum. Calculate this maximum voltage when $R=50$ ohms, $L=0.05H$, $C=20$ micro farad and $V=100$ volts.
 (b) Determine the current through $R_L=10 \Omega$ resistor as shown in figure:4 using Thevenin's theorem. Verify the same with Norton's theorem.

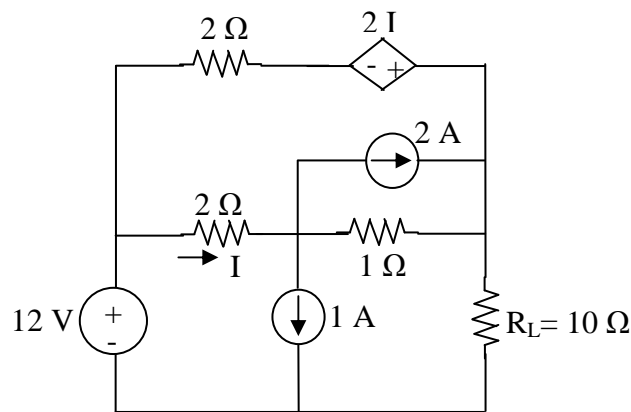
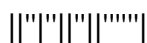

Figure:4

[6+8]



- 6.(a) Derive the symmetry and reciprocity conditions for ABCD parameters and h-parameters.
 (b) Determine the Y- parameters of the network shown in figure:5.

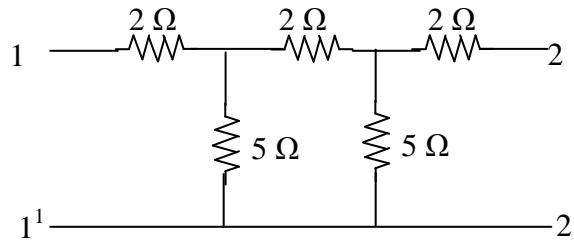

Figure:5

7. A series R-C circuit with $R=10$ ohms and $C= 2F$ has a sinusoidal voltage source $200 \sin(500t + \phi)$ applied at time when $\phi = 0$. (i) Find the expression for current (ii) At what value of ϕ must the switch be closed so that the current directly enter steady state.

[7+7]

[14]

NETWORK ANALYSIS

(Common to ECE, EIE, E Com.E Branches)

Time: 3 hours

Max. Marks: 70

Question Paper Consists of **Part-A** and **Part-B**
 Answering the question in **Part-A** is Compulsory,
 FOUR Questions should be answered from **Part-B**

PART-A

- 1.(i) Define average value, RMS value and form factor for an alternating quantity.
- (ii) Determine the source voltage and phase angle, if the voltage across the resistance is 70 V and across an inductive reactance is 20 V, in an R-L series circuit.
- (iii) For the circuit shown in figure:1, determine the value of capacitive reactance, impedance and current at resonance.

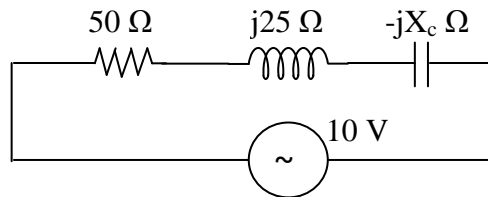

Figure:1

- (iv) State maximum power transfer theorem.
- (v) Write condition of symmetry and reciprocity for transmission, inverse transmission and inverse h-parameters.
- (vi) What is meant by natural and forced response?
- (vii) In a series R-L circuit, the application of DC voltage results in a current of 0.741 times the final steady state value of current after one second. However, after the current has reached its final value, the source is short-circuited. What would be the value of the current after one second?

[2+2+2+2+2+2+2]

PART-B

- 2.(a) For the circuit shown in figure:2, find all the branch currents using nodal analysis. Also show that total power delivered is equal to total power dissipated.

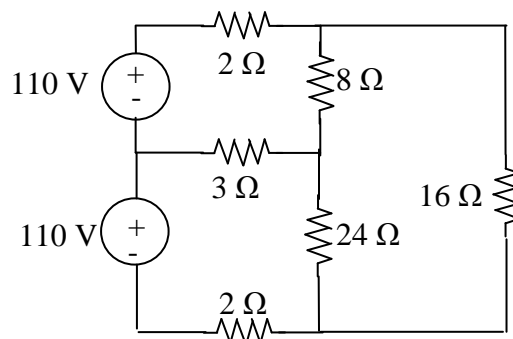

Figure 2



2.(b) A current of 5 A flows through a non inductive resistance in series with a choking coil when supplied at 250 V, 50 Hz. If the voltage across the non inductive resistance is 125V and that across the coil 200V, calculate Impedance, Reactance and Resistance of the coil, and power absorbed by the coil. Also draw the phasor diagram. [7+7]

3.(a) Define incidence matrix. For the graph shown in figure:3, find the complete incidence matrix.

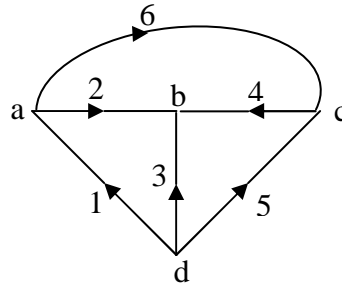

Figure:3

(b) Two impedances $Z_1=10+j31.4$ ohms and $Z_2=(10+R)+j(31.4-X_c)$ ohms are connected in parallel across a single phase AC supply. The current taken by the two impedance branches are equal in magnitude and the phase angle between them is 90° . Calculate the value of R and X_c and phase difference of the branch currents with respect to the applied voltage. [7+7]

4.(a) State and explain the Tellegen’s theorem.

(b) For the network shown in the figure:4, determine (i) Resonance frequency (ii) input admittance at resonance (iii) quality factor (iv) band width.

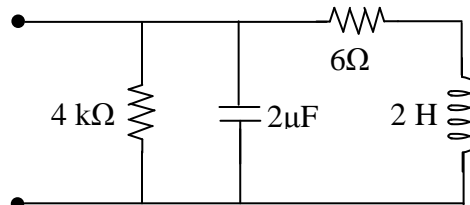

Figure:4

5.(a) Two coils A and B having turns 100 and 1000 respectively are wound side by side on closed circuit coil of X-section 8 cm^2 and mean length 80 cm. The relative permeability of iron is 900. Calculate the mutual inductance between the coils. [7+7]



- 5.(b) Determine the current through load resistance $R_L=5 \Omega$ for the circuit shown in figure:5 using Thevenin's theorem. Also find the maximum power transfer to the resistance R_L .

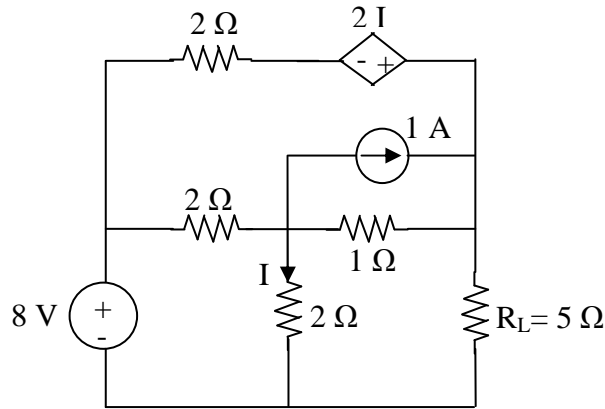

Figure:5

[7+7]

- 6.(a) Express Y-parameters in terms of ABCD and Z-parameters.
 (b) Determine the h-parameters of the following network as shown in figure:6.

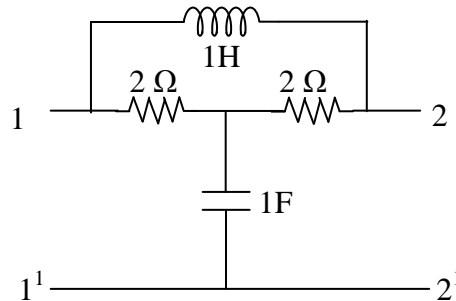
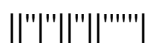

Figure:6

[7+7]

7. In a series RLC circuit, $R=6$ ohms, $L=1$ H, $C=1$ F. A DC voltage of 40 V is applied at $t=0$. Obtain the expression for $i(t)$ using differential equation approach. Explain the procedure to evaluate conditions.

[14]



NETWORK ANALYSIS

(Common to ECE, EIE, E Com.E Branches)

Time: 3 hours

Max. Marks: 70

Question Paper Consists of **Part-A** and **Part-B**
 Answering the question in **Part-A** is Compulsory,
 FOUR Questions should be answered from **Part-B**

PART-A

- 1.(i) Give the statements of Kirchhoff's voltage and current law. Write applications also.
- (ii) Write the expression for total impedance of the circuit having (i) only resistance (ii) pure inductor (iii) Pure capacitor (iv) R-L parameters (v) R-C parameters (vi) R-L-C parameters. Write the expression for phase difference in all the above cases.
- (iii) Define self, mutual inductance and coefficient of coupling.
- (iv) State superposition theorem.
- (v) Write the condition of symmetry and reciprocity for Z, Y and h-parameters.
- (vi) A resistance R and a 3 μF capacitor are connected in series across a 240 V DC supply. A voltmeter is connected across the capacitor. Calculate R so that the voltmeter reads 160 Vat 5.5 seconds after closing the switch.
- (vii) Write the expression for total inductance of the three series connected coupled coils connected between A and B as shown in figure:1.

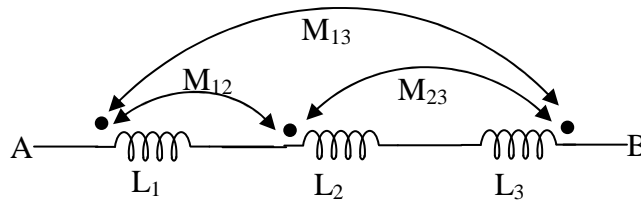

Figure:1

[2+2+2+2+2+2+2]

PART-B

- 2.(a) Determine the voltage V in the circuit shown in figure:2.

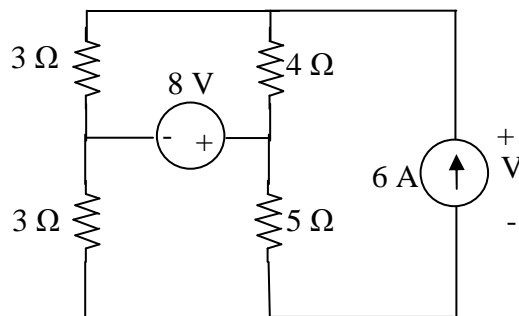

Figure:2



2.(b) An inductive load connected to a 230 V, 50 Hz source takes a current of 15 A and dissipates 2000 W. Determine the power factor of the load. Also determine the parallel capacitance required to improve power factor to 0.9 lagging. What would be the total current taken from the supply.

[7+7]

3.(a) Find i_l in circuit shown in figure:3, using nodal analysis. Assume the supply voltage $V(t)=20 \cos(4t)$ volts.

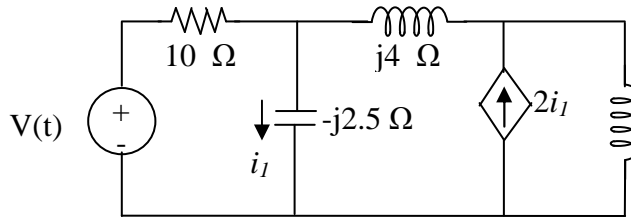

Figure:3

(b) A coil having a resistance of 50 ohms and an inductance of 0.02 H is connected in parallel with a capacitor of 25 μ F, across a 200 V, 50 Hz supply. Find the current in the coil and the capacitor. Also find the total current taken from the supply, the overall power factor and total power consumed. Draw the phasor diagram.

[7+7]

4.(a) In a series RLC circuit with variable capacitance, the current is at maximum value with capacitance of 20 μ F and the current reduces to 0.707 times the maximum value with a capacitance of 30 μ F. Find the values of R and L. What is the bandwidth of the circuit if supply voltage is $V(t)=20 \sin(6280t)$ volts?

(b) State and explain Reciprocity and Compensation theorems.

[7+7]

5.(a) Show that the resonant frequency ω_0 of an RLC series circuit is the geometric mean of ω_1 and ω_2 , the lower and upper half-power frequencies respectively.

(b) Verify the Tellegen's theorem for the circuit shown in Figures:4.

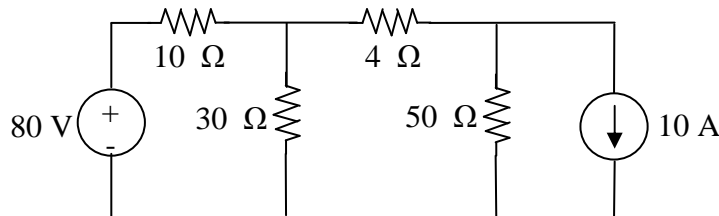
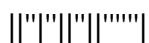

Figure:4

[7+7]



- 6.(a) Express z -parameters in terms of h -parameters and $ABCD$ -parameters.
 (b) Determine the Z -parameters for the network shown in fig:5.

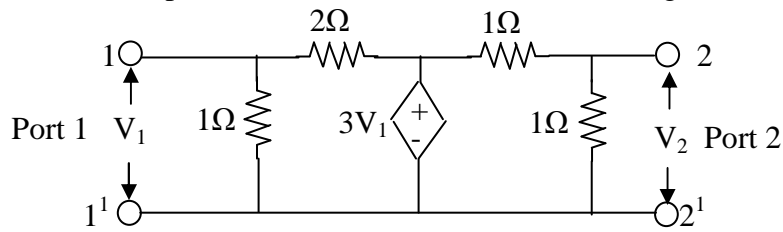
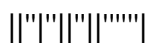

Figure:5

[7+7]

7. For an R-L series circuit, a sinusoidal voltage $v(t) = V_m \sin(\omega t + \phi)$ is applied at $t=0$. Find the expression for transient current.

[14]



II B. Tech I Semester Model Question Paper Sept - 2017

NETWORK ANALYSIS

(Common to ECE, EIE, E Com.E Branches)

Time: 3 hours

Max. Marks: 70

Question Paper Consists of **Part-A** and **Part-B**
 Answering the question in **Part-A** is Compulsory,
 FOUR Questions should be answered from **Part-B**

PART-A

- 1.(i) Define Tie-set, Cut-set and incidence matrix
- (ii) Explain why current leads the voltage by 90° in case of ideal capacitor and current lags the voltage by 90° in case of ideal inductor.
- (iii) Two coupled coils with $L_1=0.01$ H and $L_2=0.04$ H and $K=0.6$ are connected in four different ways. Find the equivalent inductance if coils are connected in (a) series aiding (b) series opposing (c) parallel aiding (iv) parallel opposing.
- (iv) State substitution theorem.
- (v) Construct circuits that realize the following Z-parameters: $Z = \begin{bmatrix} 12 & 4 \\ 4 & 8 \end{bmatrix}$
- (vi) Why current in the inductor and voltage across the capacitor does not change instantaneously.
- (vii) How the R-L-C circuit behaves for the frequencies above and below the resonant frequencies.

[2+2+2+2+2+2+2]

PART-B

- 2.(a) Define average value, RMS value, form factor and peak factor and calculate the same for the following periodic waveform shown in figure:1.

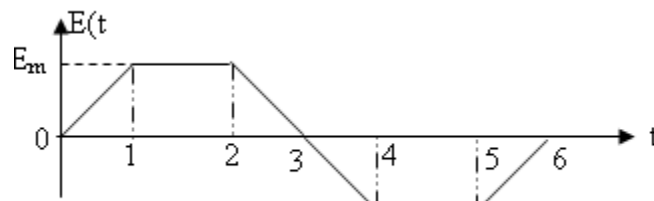

Figure:1

- (b) A series circuit consisting of non-inductive resistance and a choking coil are connected across a 250 V, 50 Hz supply. If the voltage across the resistance is 120 V and across the coil is 190 V, draw the phasor diagram and calculate (i) impedance, reactance and resistance of the coil (ii) the power absorbed by the coil (iii) the total power.

[7+7]

- 3.(a) Find the total power delivered in the circuit using mesh analysis for the circuit shown in figure:2.

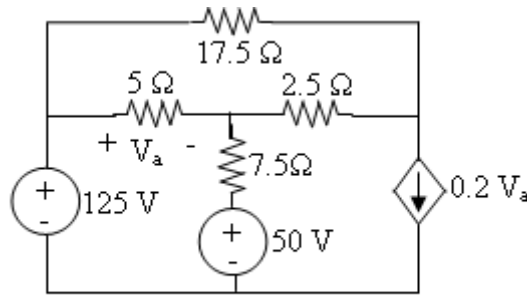

Figure:2

- (b) A series RLC circuit with $R = 10$ ohms, $L = 0.4$ H and $C = 50 \mu\text{F}$ has applied voltage of 200V with variable frequency. Calculate the resonant frequency, current at resonance, voltage across R, L and C. Also calculate the Q-factor, upper and lower half power frequencies and bandwidth. [7+7]
- 4.(a) A series combination of R and C is in parallel with a 25 ohms resistor. A 50 Hz source results in a total current of 6.5 A, a current of 5 A through 25 ohms resistance and a current of 2.3 A in the R-C branch. (i) Draw the phasor diagram of the circuit and find values of R and C (ii) Find apparent, active, reactive power and power factor of the circuit.
- (b) Determine voltage V across a 15 ohms resistor in the magnetically coupled circuit shown in Figure:3. Take $V_s = 30\angle 40^\circ$.

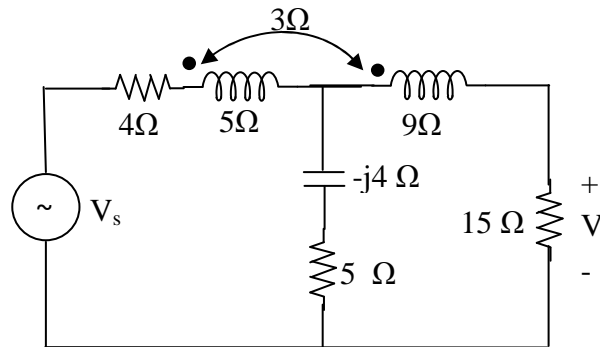
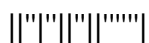

Figure:3

- 5.(a) The Z-parameters of a two port network are $Z_{11}=15 \Omega$, $Z_{22}=24 \Omega$, $Z_{12}=Z_{21}=6 \Omega$. Determine ABCD and h-parameters. [7+7]



- 5.(b) Find the voltage across $-j20 \Omega$ capacitor using superposition theorem in below Figure:4. All impedance values are in ohms.

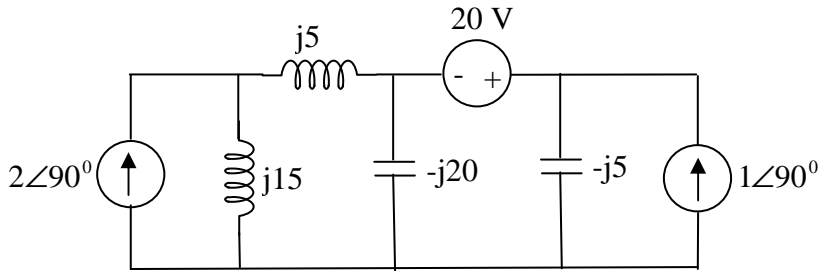

Figure:4

[7+7]

- 6.(a) Prove that the power transfer to the load becomes maximum when the load impedance is equal to the complex conjugate of the Thevenin's impedance.
 (b) Determine the ABCD parameters of the network shown in figure:5.

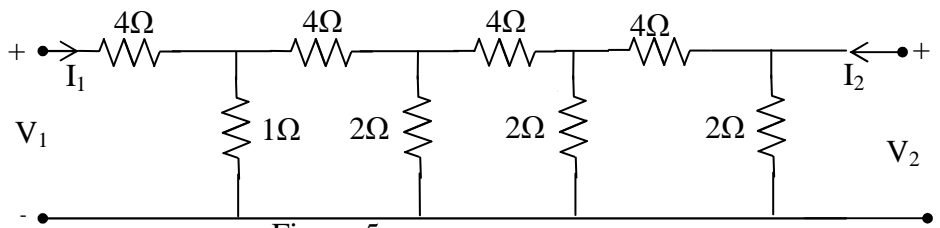
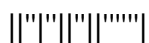

Figure:5

[7+7]

7. For an RC series circuit, a sinusoidal voltage $v(t) = V_m \sin \omega t$ is applied at $t=0$. Find the expression for transient current using both differential equation approach and Laplace transform approach.

[14]



II B. Tech I Semester Regular Examinations, October/November - 2017

NETWORK ANALYSIS

(Com to ECE, EIE and ECC)

Time: 3 hours

Max. Marks: 70

- Note: 1. Question Paper consists of two parts (**Part-A** and **Part-B**)
 2. Answer **ALL** the question in **Part-A**
 3. Answer any **FOUR** Questions from **Part-B**
- ~~~~~

PART -A

1. a) Derive an expression of the energy stored in an inductor. 2M
- b) Why an impedance represented by a complex number? How is complex impedance dependent on frequency? 3M
- c) A coil of impedance $R + jX_L$ is in parallel with a capacitor of $C = 10 \mu\text{F}$. If $R = 10 \Omega$ and $L = 0.1 \text{ H}$. find the frequency at which it resonates, if connected to a variable frequency source. 3M
- d) List out the applications and limitations of Millman's theorem. 2M
- e) State driving point impedance and driving point admittance. 2M
- f) Define transient response. 2M

PART -B

2. a) Prove that in a linear graph, every cut-set has an even number of branches in common with every loop. 7M
- b) In the network shown below, find all branch currents and voltage drops across all resistors. 7M

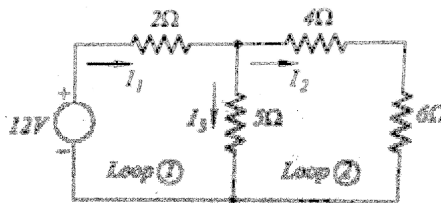

3. a) Explain the method of representing alternating quantities as phasor quantities. What are the advantages of phasor representation? 7M
- b) A resistance of 12Ω and an inductance of 0.025 H are connected in series across a 50 Hz supply. What values of resistance and inductance when connected in parallel will have the same resultant impedance and pf? Find the current in each case when the supply voltage is 230 V . 7M



4. a) Explain about the concept of series R-L resonant circuit. 5M
- b) A series RLC circuit takes a maximum current of 0.3 A at 200 V, 50 Hz. If the voltage across the capacitor is 290V at resonance. Determine R,L,C and Q of the coil. 9M

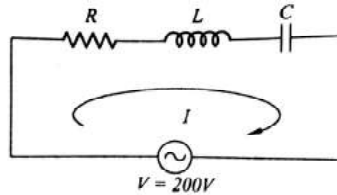

5. a) Show that under the condition of maximum power transfer, the efficiency of the circuit is 50 %. 5M
- b) Find the value of R in the circuit shown in figure such that maximum power transfer takes place. What is the amount of this power? 9M

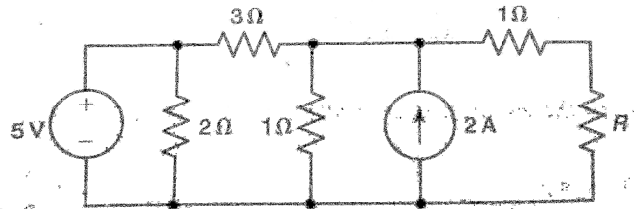

6. a) Derive expressions for the Y-parameters in terms of ABCD parameters of a two-port network. 7M
- b) Two two-port networks are connected in parallel. Prove that the overall y-parameters are the sum of corresponding individual y-parameters. 7M
7. a) Derive the non-homogeneous equation. 7M
- b) The following network is in steady state with S open. At $t = 0$, S is closed. Find $i_c(t)$ for $t > 0$. 7M

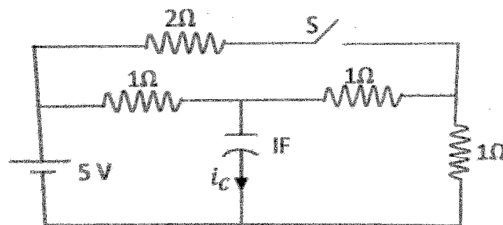

II B. Tech I Semester Regular Examinations, October/November - 2017

NETWORK ANALYSIS
(Com to ECE, EIE and ECC)

Time: 3 hours

Max. Marks: 70

- Note: 1. Question Paper consists of two parts (**Part-A** and **Part-B**)
 2. Answer **ALL** the question in **Part-A**
 3. Answer any **FOUR** Questions from **Part-B**
- ~~~~~

PART -A

1. a) Define V-shift and I-shift in the source transformation. 3M
- b) Why is a sinusoidal wave shape insisted for voltages and currents while generating transmitting and utilizing ac electric power? 2M
- c) Two coupled coils with self inductances of 1 H and 2 H are connected in series aiding. The resulting inductance L_{eq} is 4 H. Find the coefficient of coupling between them. 3M
- d) Mention some salient features of Tellegen's theorem. 2M
- e) What are the inverse transmission parameters and express their relations. 2M
- f) Define natural response 2M

PART -B

2. a) Explain the following 5M
 - i) The current through an inductor cannot change instantaneously.
 - ii) The voltage across a capacitor cannot change instantaneously.
- b) Determine the current through the impedance $(2+j3) \Omega$ in the circuit shown in figure , where $V_b = 20 \angle 0^\circ$ (V). 9M

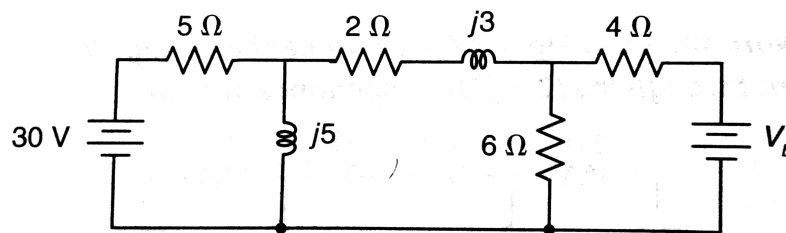

3. a) Use nodal voltage method to find the voltage of nodes 'm' and 'n' and currents through $j2 \Omega$ and $-j2 \Omega$ reactance in the network shown below 7M

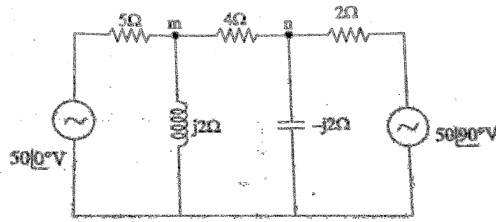

- b) The impedances of a parallel circuit are $Z_1=(6+j8)\Omega$ and $Z_2=(8-j6)\Omega$. If the applied voltage is 120V, find (i) current and p.f of each branch (ii) over all current and p.f of the combination. (iii) Power consumed by each impedance. Draw a neat phasor diagram. 7M

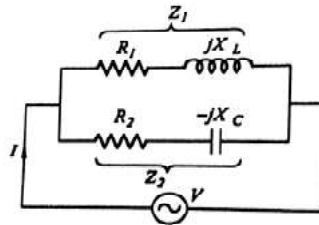

4. a) Derive the expression of the coefficient of coupling for the coupled circuit. 7M
 b) Two inductively coupled coils have self inductances $L_1= 50 \text{ mH}$ and $L_2= 200 \text{ mH}$. If the coefficient of coupling is 0.5 i) find the value of mutual inductance between the coils and ii) what is the maximum possible mutual inductance. 7M
5. a) Write the applications of superposition theorem. 5M
 b) Find the voltage across 10Ω resistance using superposition theorem. 9M

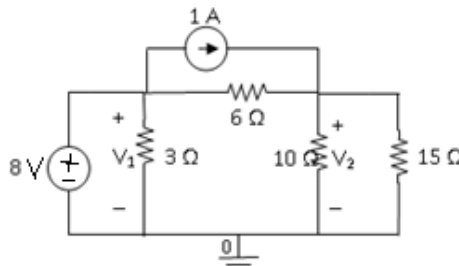

6. a) The h-parameters of a two-port network are $h_{11} = 35 \text{ ohm}$, $h_{12} = 2.6 \times 10^{-4}$, $h_{21} = -0.98$, $h_{22} = 0.3 \times 10^{-6} \text{ mho}$. The input terminals are connected to a 0.0001 V sinusoidal and a 10^4 ohm resistance is connected across the output port. Find the output voltage. 7M
 b) The network shown in figure contains both dependent current source and a dependent voltage source. For this circuit, determine the y and z parameters. 7M

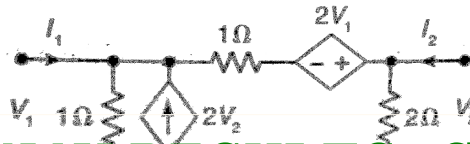

7. a) Derive the homogeneous equation. 5M
- b) In the following network the switch s is open and steady state is reached. At $t = 0$, S is closed. Find $i_L(t)$ for $t > 0$. 9M

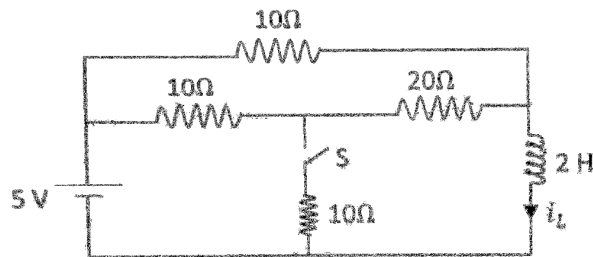

II B. Tech I Semester Regular Examinations, October/November - 2017

NETWORK ANALYSIS

(Com to ECE, EIE and ECC)

Time: 3 hours

Max. Marks: 70

- Note: 1. Question Paper consists of two parts (**Part-A** and **Part-B**)
 2. Answer **ALL** the question in **Part-A**
 3. Answer any **FOUR** Questions from **Part-B**

PART -A

1. a) Comment briefly on the choice between loop and node methods of analyzing a network. 3M
- b) Mention some important characteristics of an ideal capacitor. 2M
- c) Compare the properties of series and parallel resonance circuits. 3M
- d) State and explain the substitution theorem. 2M
- e) What do you understand by a reciprocal network? What is a symmetrical network? 2M
- f) State the advantages of Laplace transform application to the solution of electric circuits. 2M

PART -B

2. a) Explain duality in electrical engineering. State the steps followed in finding the dual of a network. 7M
- b) For a half wave rectified alternating current find i) Average value, ii) RMS value, iii) Form factor, and iv) Peak factor. Find the average and RMS values when I_m is 3A. 7M
3. a) Obtain the star connected equivalent circuit of the delta connected circuit. 7M
- b) Obtain the delta connected equivalent for the star connected circuit shown in figure 7M

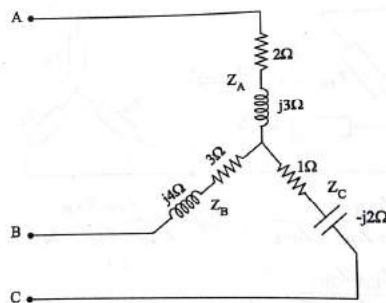

4. a) Explain the impedance transformation in an ideal transformer to achieve maximum power transfer. 7M
- b) Two coils connected in series have an equivalent inductance of 0.4H when connected in aiding, and an equivalent inductance of 0.2H when the connection is opposing. Calculate the mutual inductance of the coils. 7M



5. a) State Thevenin's theorem, and write the applications. 5M
 b) Find the current through $8\ \Omega$ resistance for the network shown using Thevenin's theorem. 9M

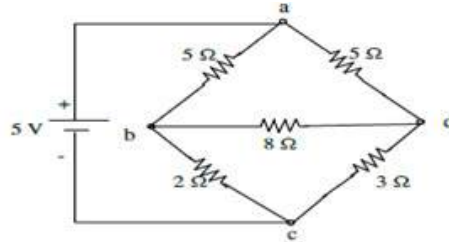

6. a) Two two-port networks are connected in cascade. Prove that the overall transmission parameter matrix is the product of individual transmission parameter matrices. 7M
 b) Construct ABCD parameters. 7M

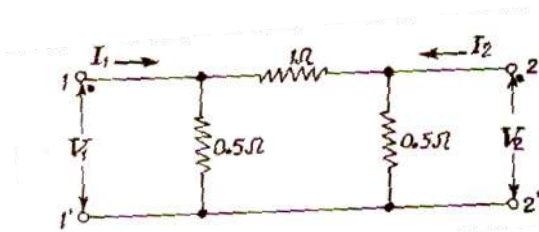

7. In the series circuit shown in figure the switch is closed on position 1 at $t = 0$. At $t = 1\ \text{ms}$, the switch is moved the position 2. Obtain the equations for the current in both intervals and draw the transient current waves. 14M

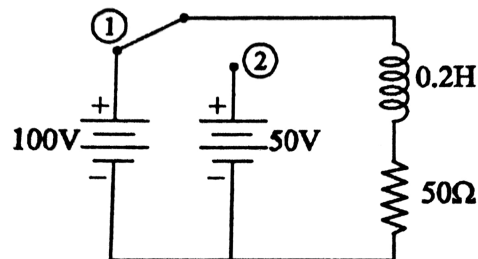

II B. Tech I Semester Regular Examinations, October/November - 2017

NETWORK ANALYSIS
(Com to ECE, EIE and ECC)

Time: 3 hours

Max. Marks: 70

- Note: 1. Question Paper consists of two parts (**Part-A** and **Part-B**)
 2. Answer **ALL** the question in **Part-A**
 3. Answer any **FOUR** Questions from **Part-B**
- ~~~~~

PART -A

1. a) What is the difference between circuits and networks? 2M
- b) Draw the phasor diagrams for resistor, ideal inductor and ideal capacitor. 2M
- c) At resonance, the current is maximum in a series circuit and minimum in a parallel circuit. Why? 2M
- d) Discuss about Norton's theorem and write its applications. 2M
- e) What are transmission parameters? Where are they most efficiently used. 3M
- f) Write the expression for transient current for series RL and RC circuits? 3M

PART -B

2. a) Show that for a network graph with P separate parts, n nodes and b branches, the number of chords C is given as $C = b - n + P$ 7M
- b) Find voltage across 12Ω resistance in the below figure. 7M

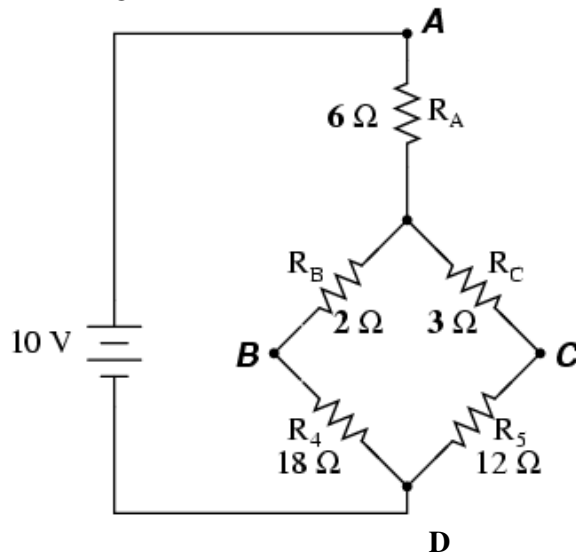

3. a) Explain about the steady state analysis of resistance in parallel combination with sinusoidal excitation. 7M
- b) A pure inductance of 3 mH carries a current of the waveform shown in figure. Sketch the wave form of $V(t)$ and $P(t)$. Determine the average value of power. 7M

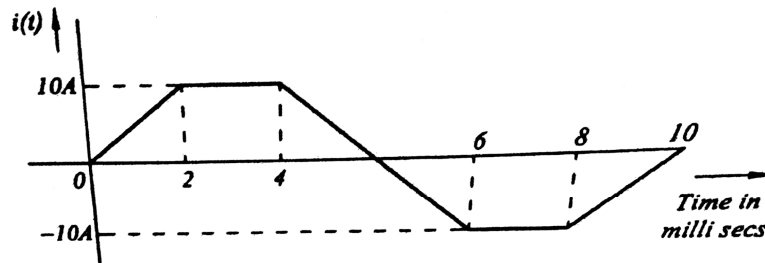

4. a) Derive the expression for bandwidth of series resonating circuit and its relation with Q . 5M
- b) An inductance of 0.5H, a resistance of 5Ω and a capacitance of $8\mu\text{F}$ are in series across a 220V ac supply. Calculate the frequency at which the current flowing through the circuit becomes maximum. Also, find bandwidth, half power frequencies and voltage across capacitance at resonance. 9M
5. a) State the reciprocity theorem as applied to a network and give a proof of the same for a general network. Mention two networks where this theorem is not applicable. 6M
- b) In the circuit shown in figure, find voltage V . Interchange the current source and resulting voltage V and show that the reciprocity theorem is verified. 8M

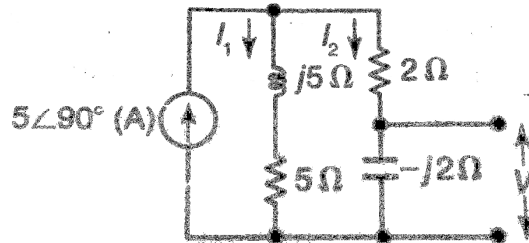

6. a) Define open circuit parameters. Explain how the open circuit parameters can be obtained for a given two port network. 7M
- b) A two port network has the following parameters: $Z_{11}=6\Omega$, $Z_{12}=Z_{21}=3\Omega$ and $Z_{22}=4\Omega$. Calculate hybrid parameters 7M



7. a) Determine the DC response of RL and RC circuit and sketch the voltage transients. 7M
- b) The circuit shown in figure consists of series RL elements. The sine wave is applied to the circuit when the switch is closed at $t = 0$. Determine the current $i(t)$. 7M

